

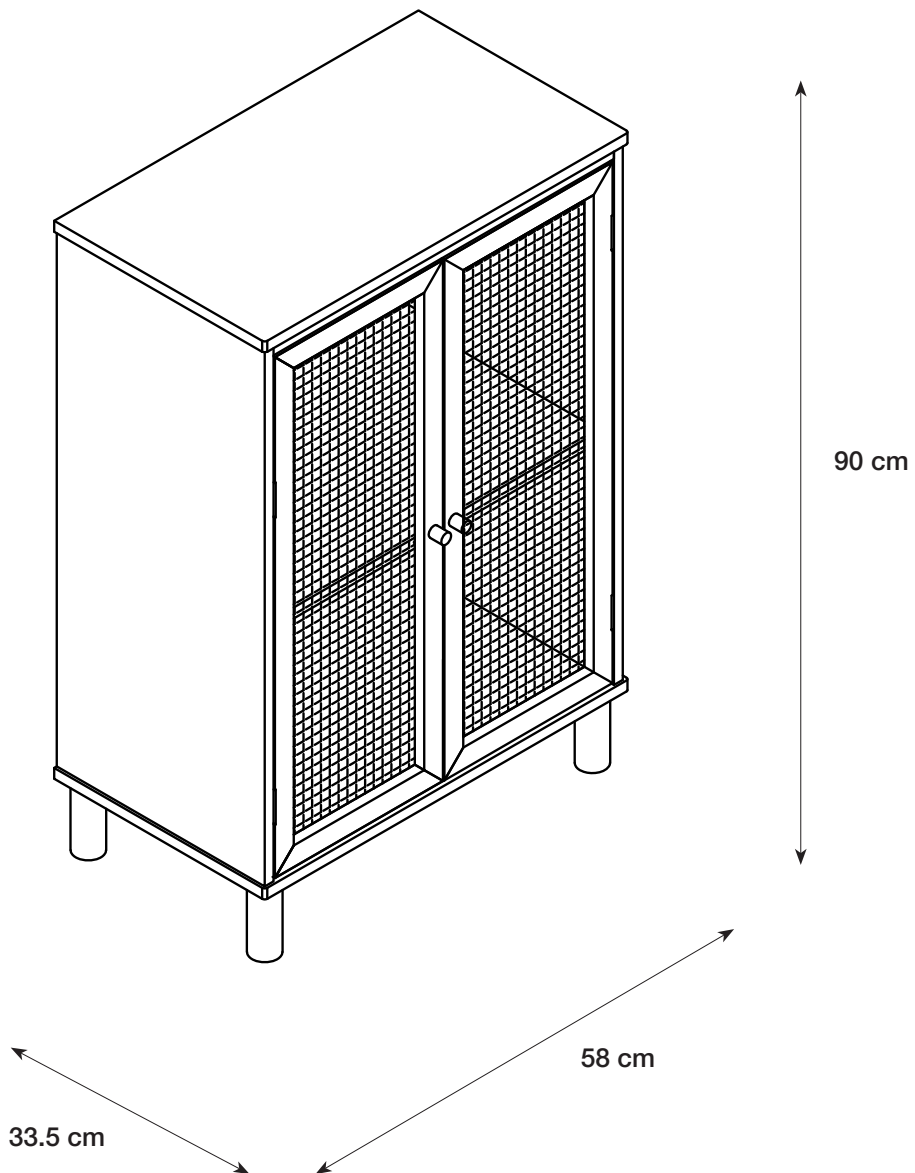

*Anna & Clara's*

## **CABINET**

SKAB • KAAPPI • SCHRANK  
KAST • ARMOIRE • ARMADIO





*Anna & Clara's*

## CABINET

SKAB • KAAPPI • SCHRANK • KAST • ARMOIRE • ARMADIO

**EN:** CABINET. W 58 x D 33,5 x H 90 cm. Flat-pack. Solid pine, rattan. Screws: iron. Read the instructions thoroughly before assembling this product. This product must be permanently fixed to the wall to avoid dangerous situations. Incorrect assembly of the product can cause it to tip over/fall down and injure people or damage things. Contact your local building merchants for advice about the correct type of screws/rawl plugs for your type of wall. The choice of screws/rawl plugs to hang the product is the customer's responsibility and at their own risk. Clean with a well wrung-out cloth.

**DA:** SKAB. B 58 x D 33,5 x H 90 cm. Saml selv. Massiv fyrretræ, rattan. Skruer: jern. Læs brugsvejledningen grundigt igennem før samling af dette produkt. Dette produkt skal permanent fastgøres til væggen for at undgå farlige situationer. Fejlmontering af produktet kan medføre, at produktet vælter/falder ned og laver skade på mennesker og ting. Kontakt dit lokale byggemarked, for vejledning omkring den korrekte type af skruer/rawplugs til din type væg. Valg af skruer/rawplugs til ophæng af produktet er på kundens eget ansvar. Rengøres med en hårdt opvredet klud.

**NO:** SKAB. B 58 x D 33,5 x H 90 cm. Flatpakket. Massiv furu, rotting. Skruer: jern. Les bruksanvisningen nøye før du setter sammen dette produkt. Dette produkt skal festes permanent i vegg for å unngå farlige situasjoner. Hvis produktet monteres på feil måte, kan det velte / falle ned og skade mennesker og gjenstander. Kontakt ditt lokale byggevarerhus for veiledning om riktig type skruer/plugger til din type vegg. Kunden har selv ansvar for å velge skruer/plugger til å henge opp produktet med. Rengjøres med en hardt oppvridt klut.

**SV:** SKAB. B 58 x D 33,5 x H 90 cm. Självmontering. Massiv furu, rotting. Skruvar: järn. Läs instruktionerna noggrant innan du monterar den här produkten. Denna produkt måste fästas permanent på väggen för att undvika farliga situationer. Felmontering av produkten kan leda till att produkten välter/faller ned och orsakar skador på människor och föremål. Kontakta din lokala bygghandel för information om korrekt typ av skruvar/expanderpluggar för just din typ av vägg. Val av skruvar/pluggar för upphängning av produkten sker på kundens egen risk. Rengörs med hårt urvriden trasa.

**FI:** KAAPPI. L 58 x S 33,5 x K 90 cm. Koottava. Massiivimäntyä, rottinki. Ruuvit: rauta. Lue käyttöohje huolellisesti ennen tämän tuotteen kokoamista. Tämä tuote on kiinnitettävä pysyvästi seinään vaarallisten tilanteiden välttämiseksi. Tuotteen virheellinen kokoaminen voi aiheuttaa tuotteen kaatumisen ja vahingoittaa ihmisiä ja/tai esineitä. Pyydä paikallisesta rautakaupasta apua seinällesi sopivien ruuvien/kiinnitystulppien valintaan. Tuotteen ripustusruuvien/tulppien valitseminen on asiakkään omalla vastuulla. Puhdistetaan kuivaksi kierrettyllä liinalla.

**DE:** SCHRANK. B 58 x T 33,5 x H 90 cm. Bausatz. Kiefer massiv, Rattan. Schrauben: Eisen. Bitte lesen Sie die Gebrauchsanweisung sorgfältig durch, bevor Sie dieses Produkt zusammenbauen. Dieses Produkt muss dauerhaft an der Wand befestigt werden, um gefährliche Situationen zu vermeiden. Eine verkehrte Montage des Produkts kann dazu führen, dass das Produkt umkippt/umfällt und Personen oder Sachen zu Schaden kommen können. Fragen Sie in Ihrem örtlichen Baufachmarkt nach den geeigneten Schrauben bzw. Dübeln für Ihre Wandart. Die Wahl der Schrauben/Dübel zum Aufhängen des Produkts erfolgt auf eigene Verantwortung des Kunden. Mit einem gut ausgewrungenem Lappen reinigen.

**NL:** KAST. B 58 x D 33,5 x H 90 cm. Zelf monteren. Massief dennenhout, rotan. Schroeven: ijzer. Lees de gebruiksaanwijzing zorgvuldig door voordat u dit product in elkaar zet. Dit product moet permanent aan de muur worden bevestigd om gevaarlijke situaties te voorkomen. Onjuiste montage kan ertoe leiden dat het product kantelt/omvalt en schade aan mensen en voorwerpen veroorzaakt. Neem contact op met de plaatselijke doe-het-zelfzaak voor advies over het juiste type schroef of plug voor uw type muur. De keuze van schroeven/pluggen voor het ophangen van het product is de eigen verantwoordelijkheid van de klant. Schoonmaken met een goed uitgewrongen doek.

**FR:** ARMOIRE. L 58 x P 33,5 x H 90 cm. À monter soi-même. Pin massif, rotin. Vis: fer. Lisez attentivement les instructions avant de monter ce produit. Ce produit doit être fixé au mur afin d'éviter les situations dangereuses. Un montage incorrect du produit peut le faire basculer ou tomber et blesser des personnes et causer des dommages aux biens. Contactez vos commerçants en construction locaux pour obtenir des conseils quant aux types de vis et de chevilles adéquats pour votre type de mur. Le choix des vis ou des chevilles de type Molly adéquates pour accrocher le produit est de la responsabilité du client. Nettoyer à l'aide d'un chiffon bien essoré.

**IT:** ARMADIO. L 58 x P 33,5 x H 90 cm. Montaggio a cura dell'utente. Pino massello, rattan. Viti: ferro. Leggere accuratamente le istruzioni prima di assemblare il prodotto. Per evitare situazioni di pericolo, fissare questo prodotto in modo permanente a una parete. L'assemblaggio errato del prodotto può causare il ribaltamento/la caduta del prodotto procurando danni a persone e cose. Per informazioni sul tipo di viti/tasselli più adatto alla vostra parete contattate i rivenditori locali di materiale edile. La scelta delle viti/dei tasselli utilizzati per appendere il prodotto è responsabilità del cliente. Pulire con un panno ben strizzato.

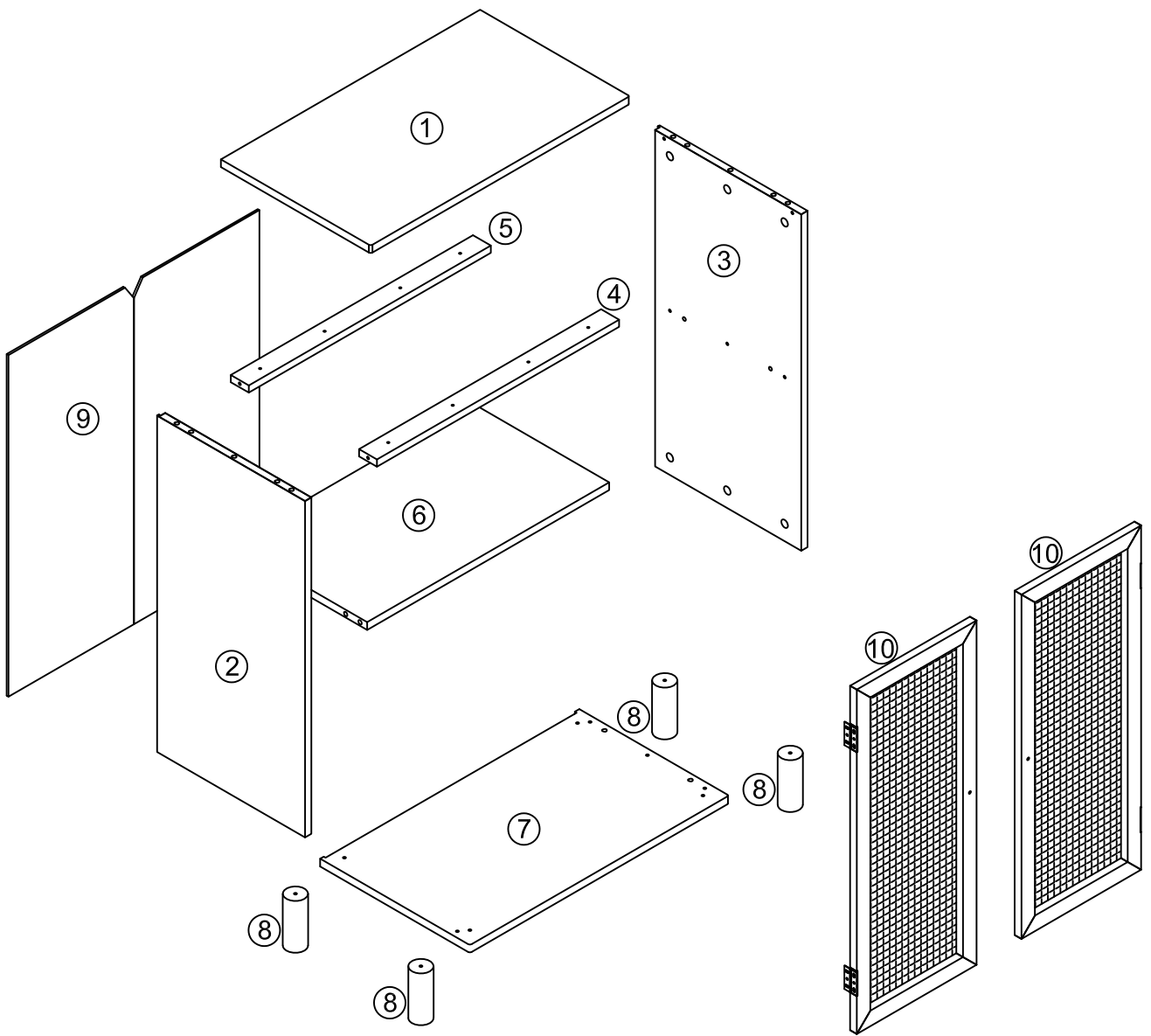

Ax22 

Bx22 

Cx12 

Dx4 

Ex2 

Fx8 

Gx44 

Hx1 

Jx2 

Kx4 



Lx2 

Mx2 

Nx1 



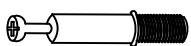

Px4 

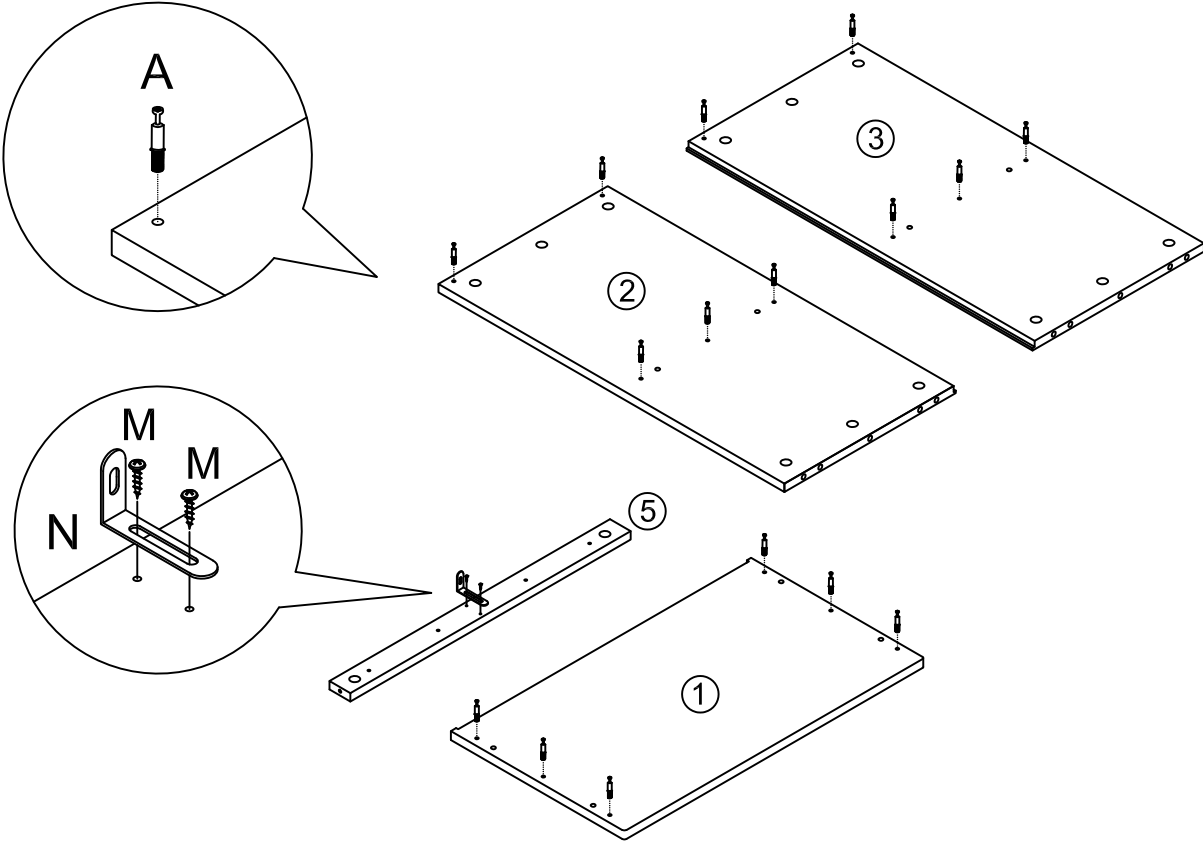
1

Ax16		Mx2		Nx1	
------	---	-----	---	-----	---

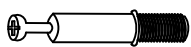

2

Ax6		Dx4		Hx1		Px4	
-----	---	-----	---	-----	--	-----	---

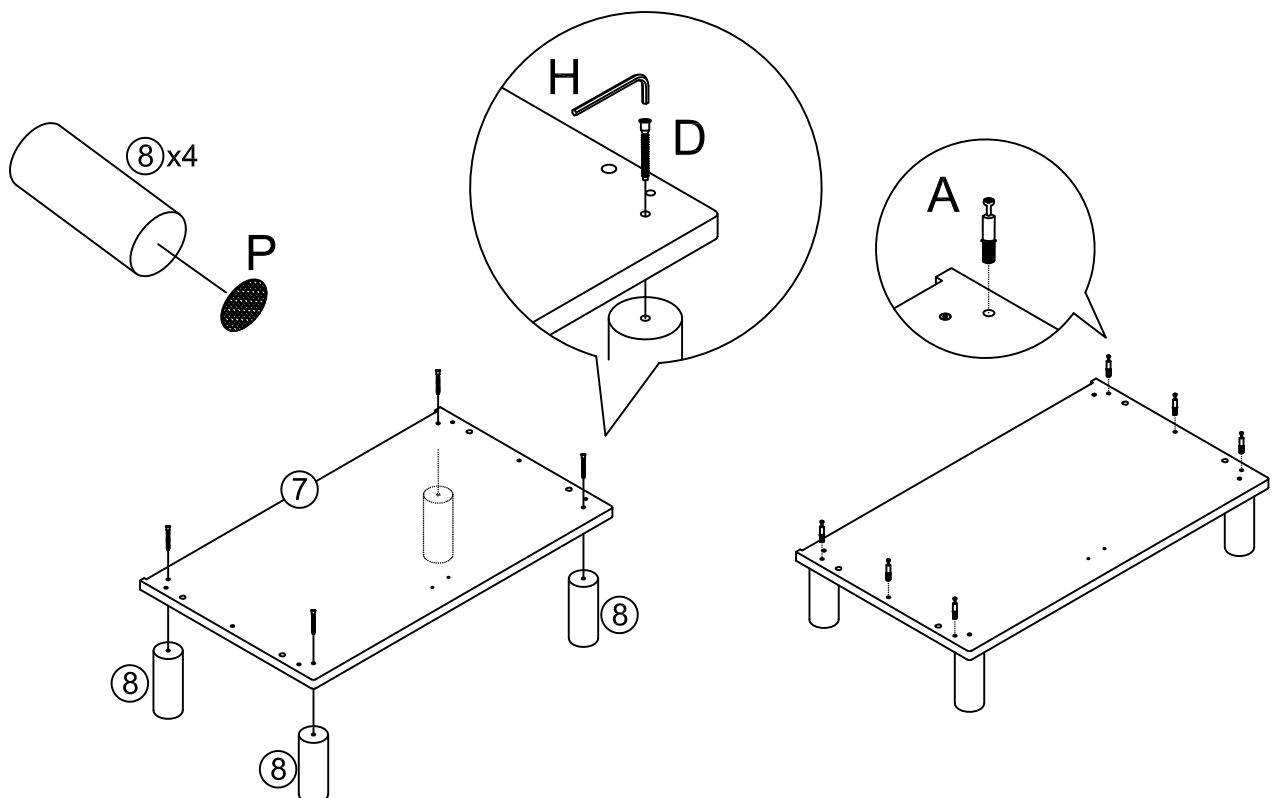

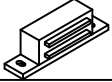

3

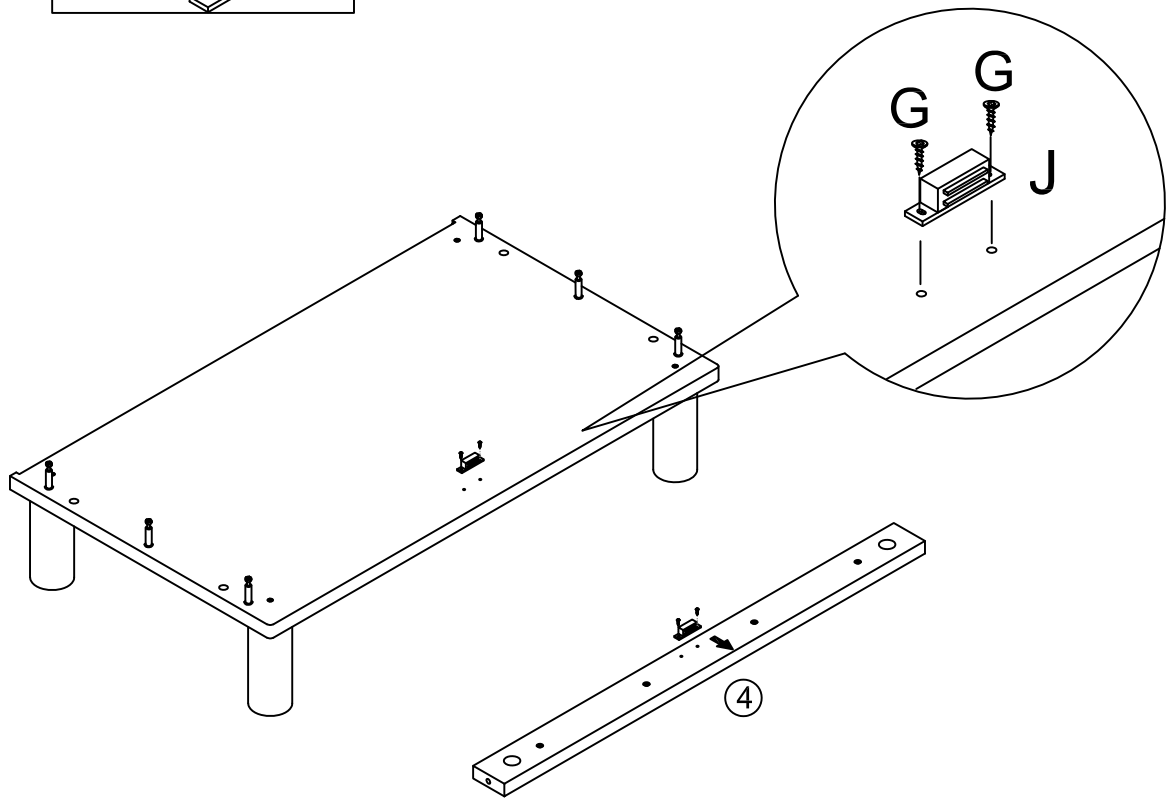
Gx4	
Jx2	



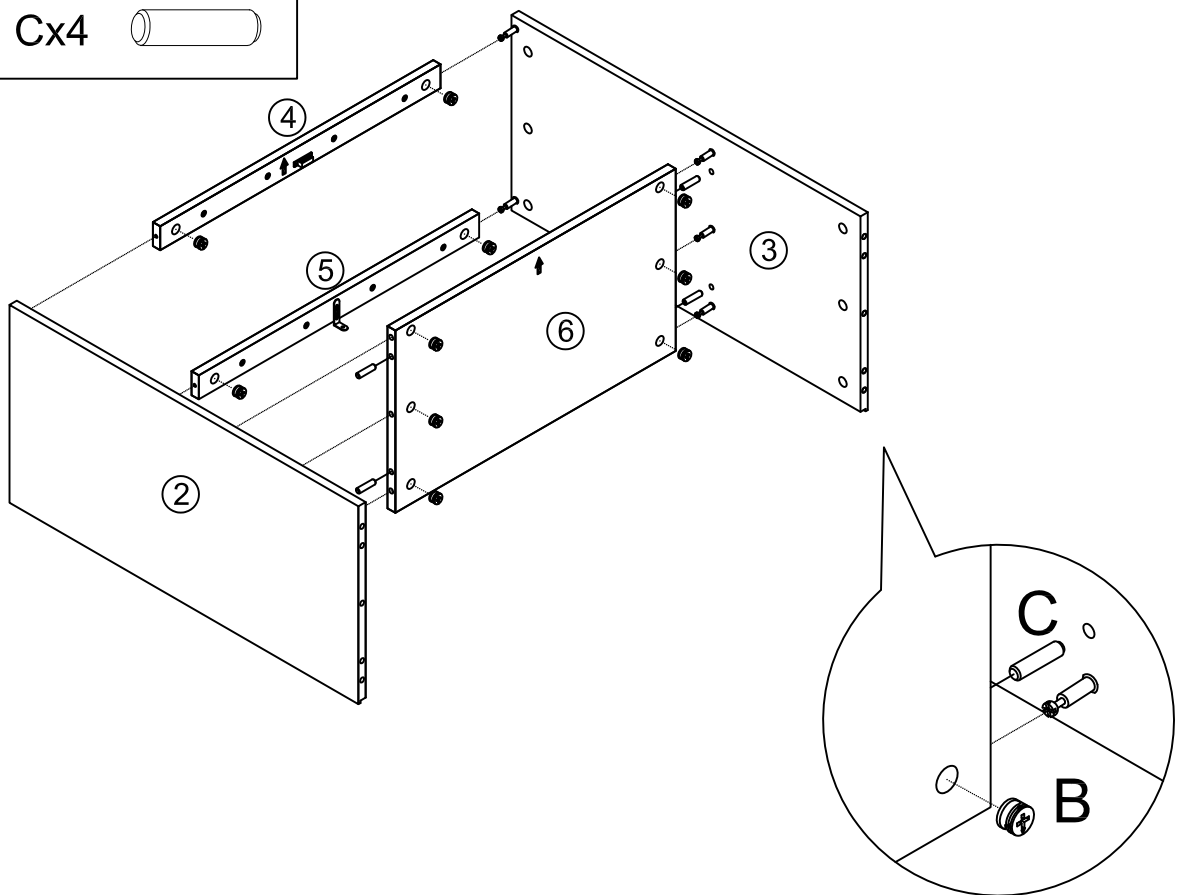

4

Bx10	
Cx4	

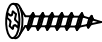

5

Bx10 	Fx8 
Cx4 	

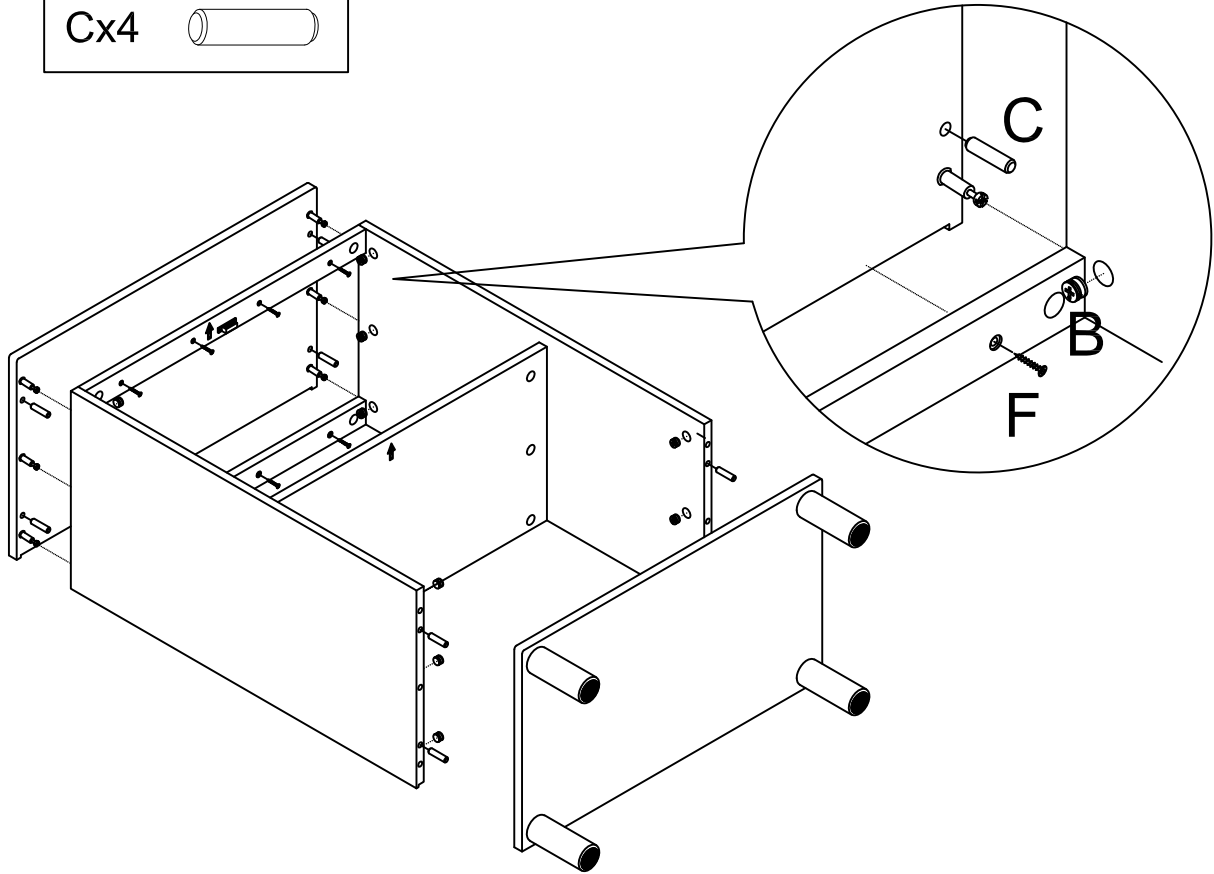

6

Gx20 
--

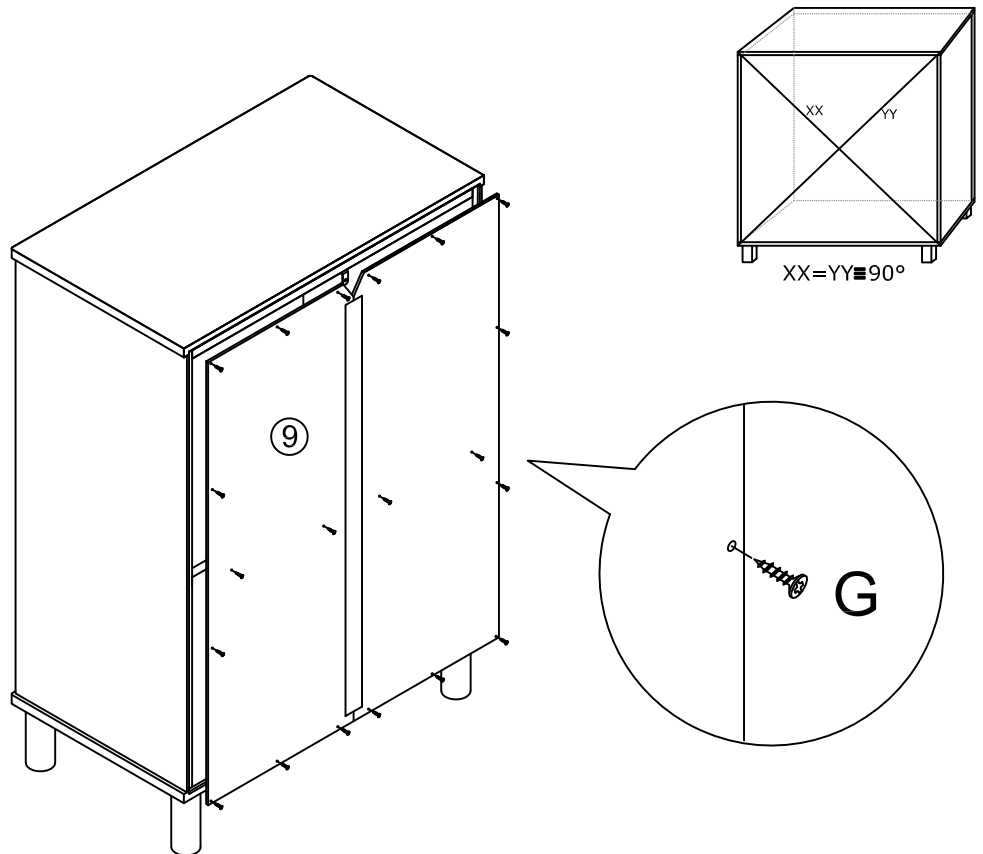

7

Ex2 	Gx4 
Lx2 	Kx4 

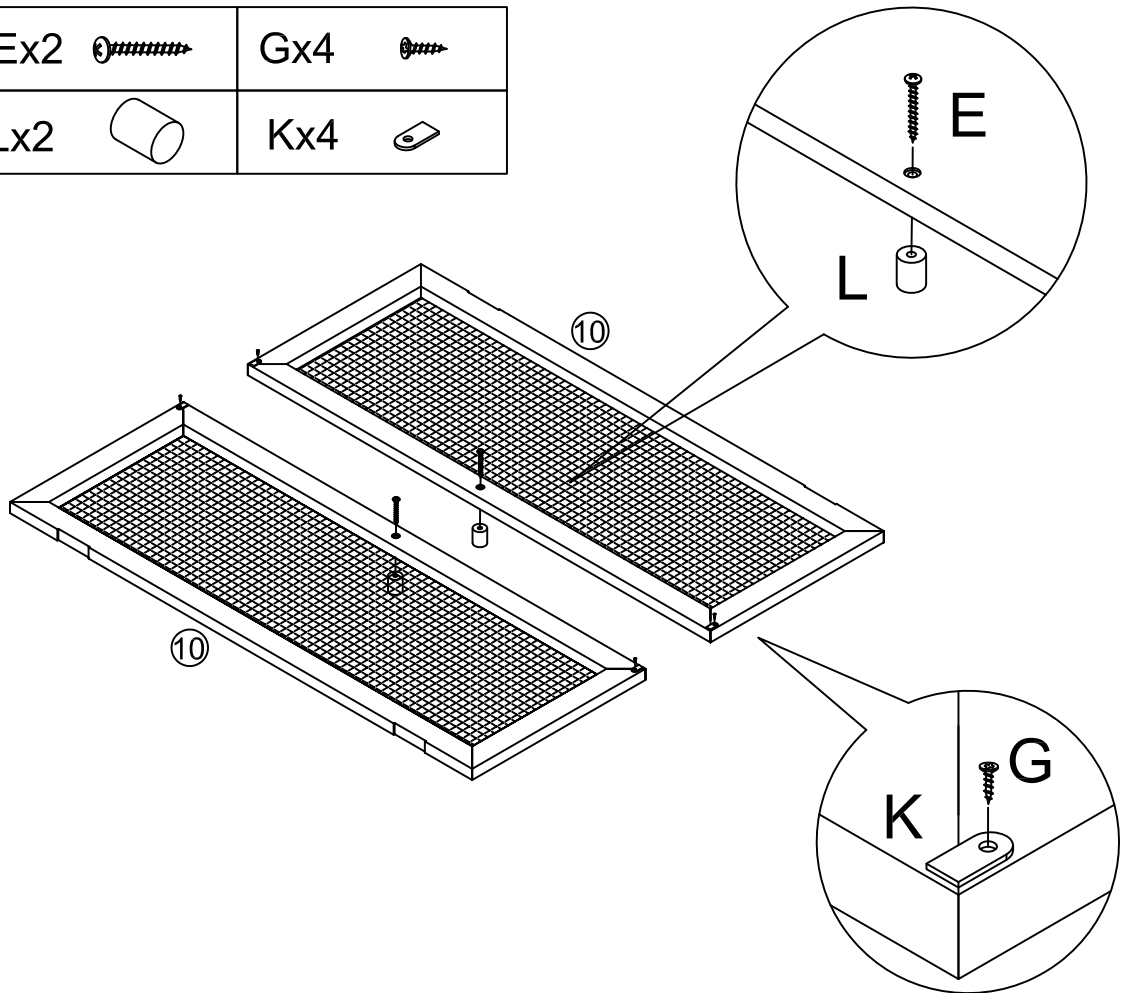

8

Gx8 
---

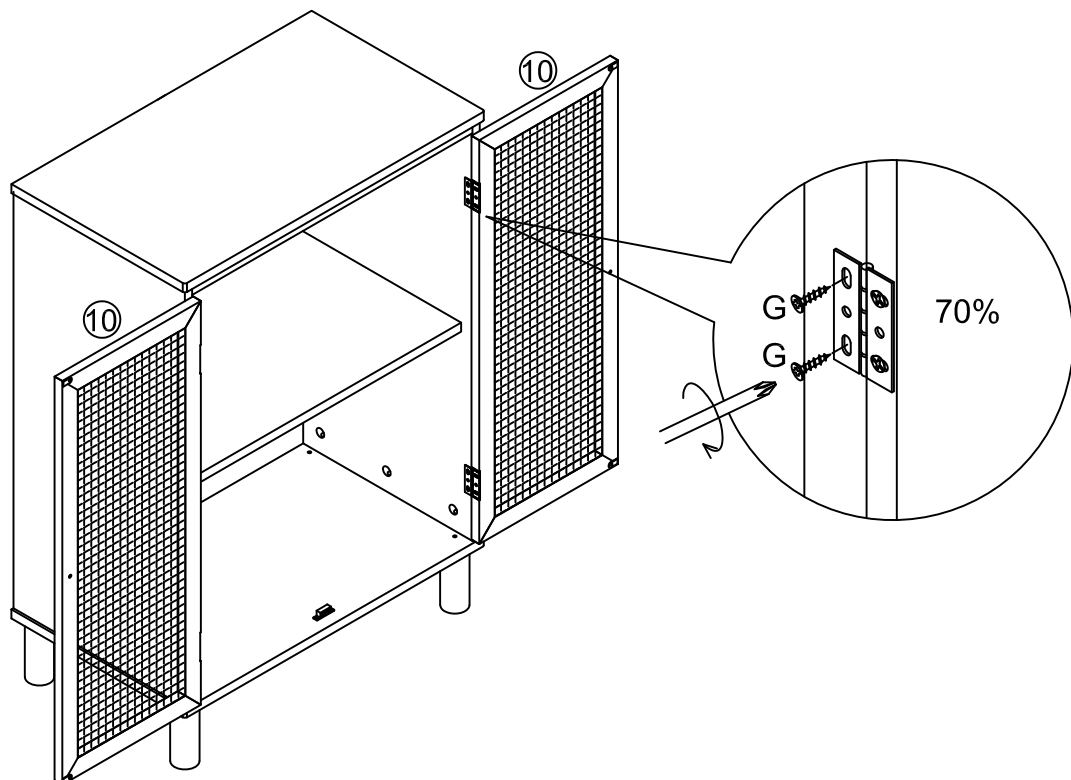

9

Gx8 

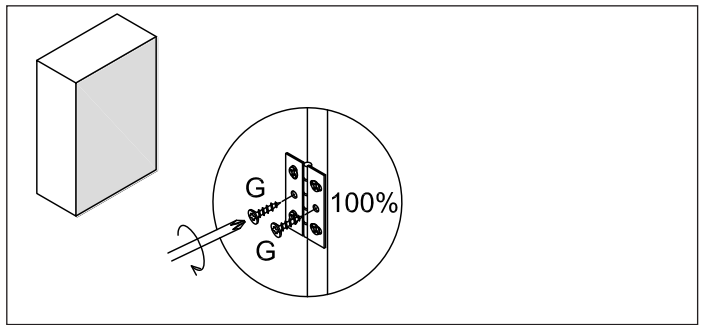
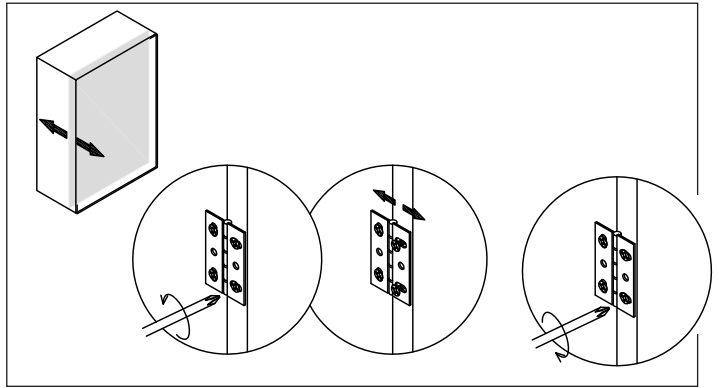
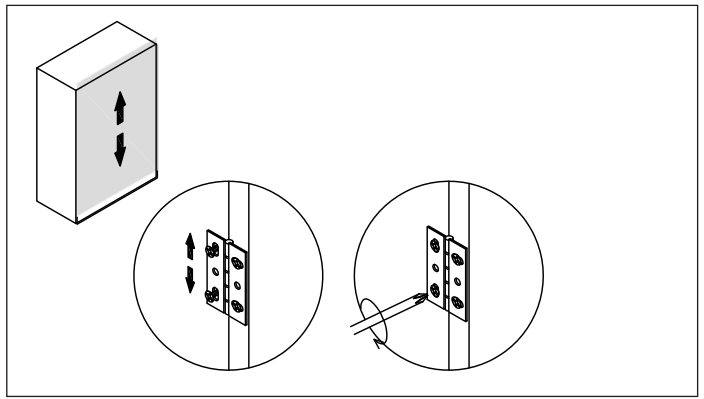
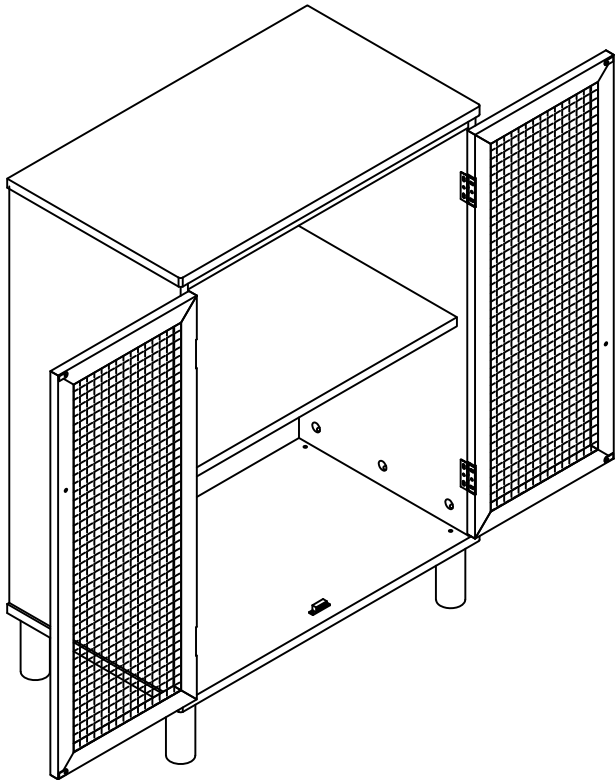

10

